

HOW TO MEASURE A BOW HEIGHT

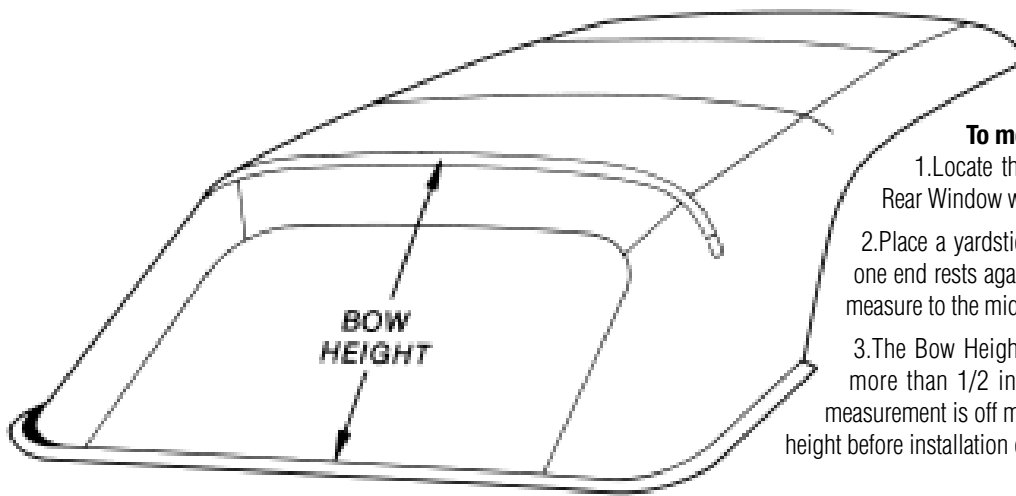

Check Bow Height Measurement BEFORE removing the old Top from your customer's car.

To measure:

1. Locate the bottom center of the existing Glass or Plastic Rear Window where it meets the inner edge of the belt molding.
2. Place a yardstick or metal ruler flat against the Rear Window so one end rests against the inner edge of the rear finish molding, and measure to the middle of the rear bow.
3. The Bow Height measurement you have taken should not vary more than 1/2 inch from the figure listed in our Catalog. If the measurement is off more than 1/2 inch, reset the rear bow to the correct height before installation or our top and rear window will not fit correctly.

HIDEM AND WIRE-ON TRIM

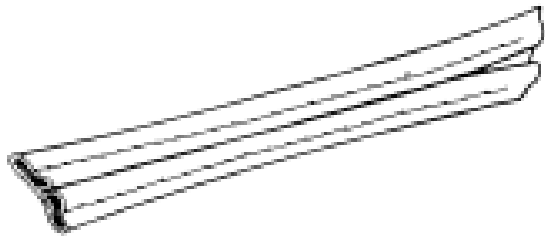

Vinyl or Cloth Hidem

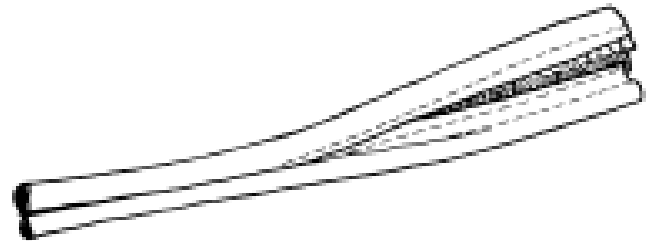

Vinyl or Cloth Wire-On

Many older Imported and nearly all Pre-1991 American Car Convertible Tops used Hidem or Wire-On trim across the rear bow.

HIDEM: Available in all CG Bison Crush Grain Vinyl colors, most BS Everflex British Vinyl colors, KV BKB and KV WHB, most colors of our Robbins RC Cabrio Grain Vinyl, and most colors of our Sun-Fast Cloth.

WIRE-ON: Available in many colors of our KV Grain Vinyl, CG BKB and CG WHB in our Crush Grain Vinyl, CH BKB and CH WHB Chrysler Crush Grain Vinyl, some colors of Sailcloth Single Texture Vinyl; and in Black, Blue, and Brown shades of our Sun-Fast Cloth.

PLASTIC INSERT WIRE-ON: Available in Black, Oxford White, GM White, Ford White and other KV Grain Colors.

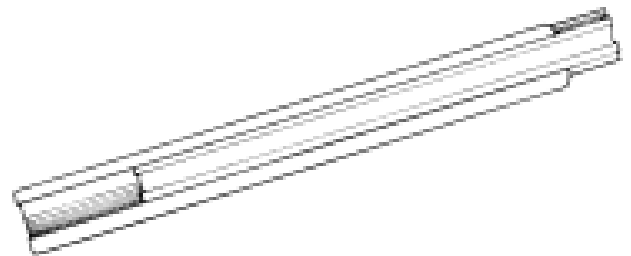

Plastic Insert Wire-On

Sales Materials and Installation Videos

We have been producing Convertible Top installation training videos to assist trimmers installing our products for several years. The following Videos are available now, and we plan to make additional videos in the future.

Item Number	Description
VIDEO 2040	1972-89 Mercedes SL Top Installation.
VIDEO 2710	1987-93 BMW 325i Top Installation.
VIDEO 7409	1987-93 Cadillac Allante Top and Headliner Installation.
DECAL	Robbins Convertible Top Decal for Trim Shops to display.
SAMPLE SET	Topping Sample Set mounted with screw posts to page lifter for use in binders.

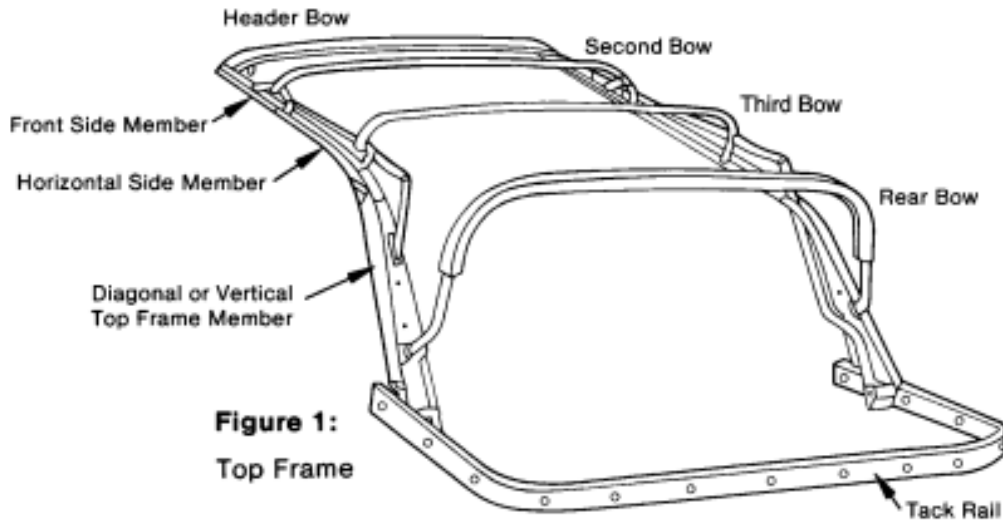

Figure 1:
Top Frame

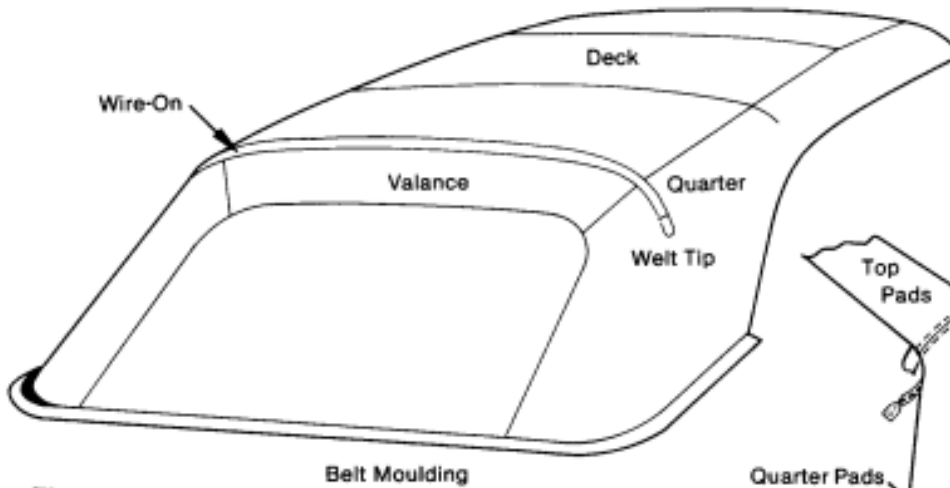

Figure 3:
Typical American Car Top, Outside View

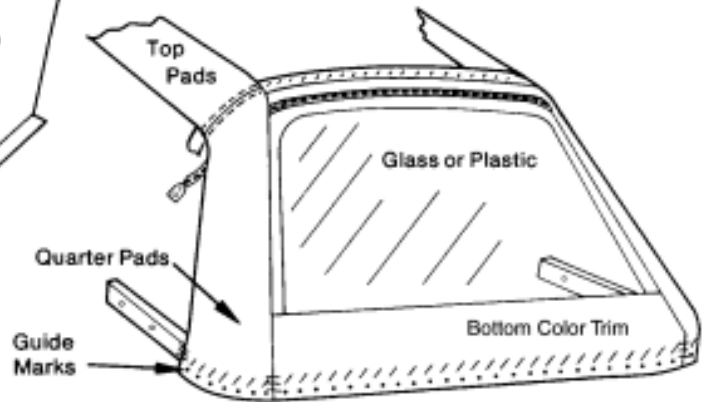
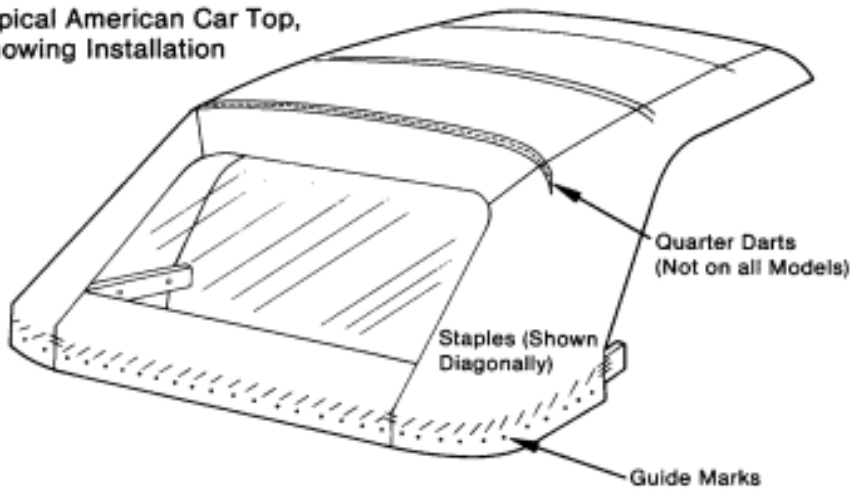

Figure 4:
Typical Rear Curtain Assembly Showing
Partial Top Pads, Quarter Pads, and Tack Rail.

Figure 6:
Typical American Car Top,
Showing Installation



TYPICAL TOP AND TOP FRAME DIAGRAMS

This series of diagrams is presented for the purpose of helping our customers better understand the terminology used to describe Convertible Tops, Glass and Plastic Rear Windows, Top Frames, etc. These diagrams are universal, and while no one diagram will show full details of a specific top, almost any part of any top will appear in one of these diagrams.

Figure 2:
Top, Inside View

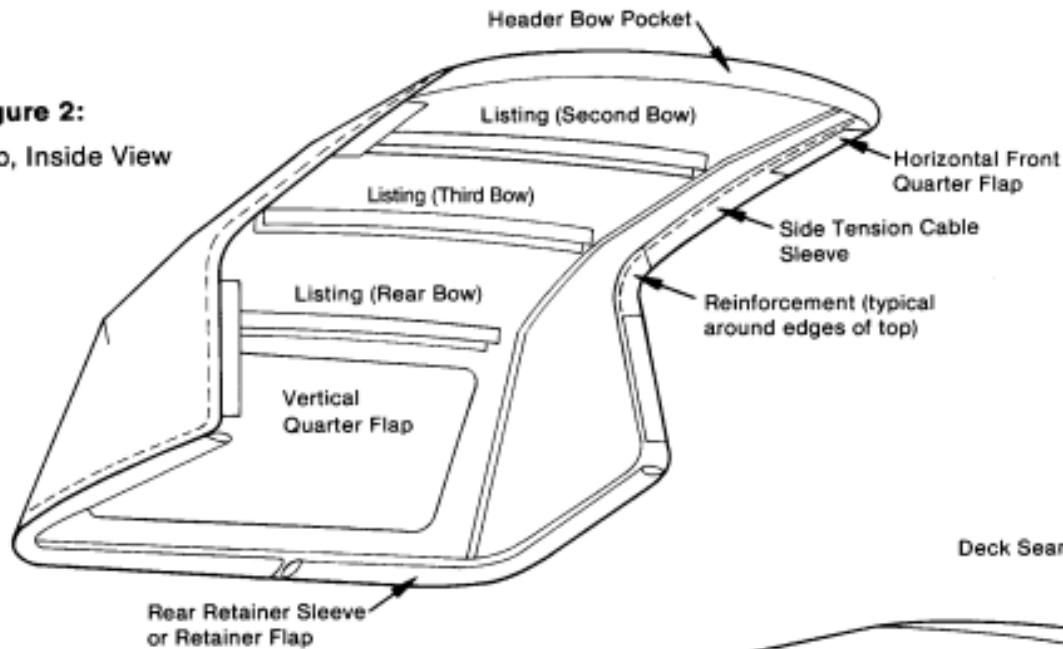

Figure 5:
Typical Import Car Top with Frame Mounted Door Glass Weatherseals.

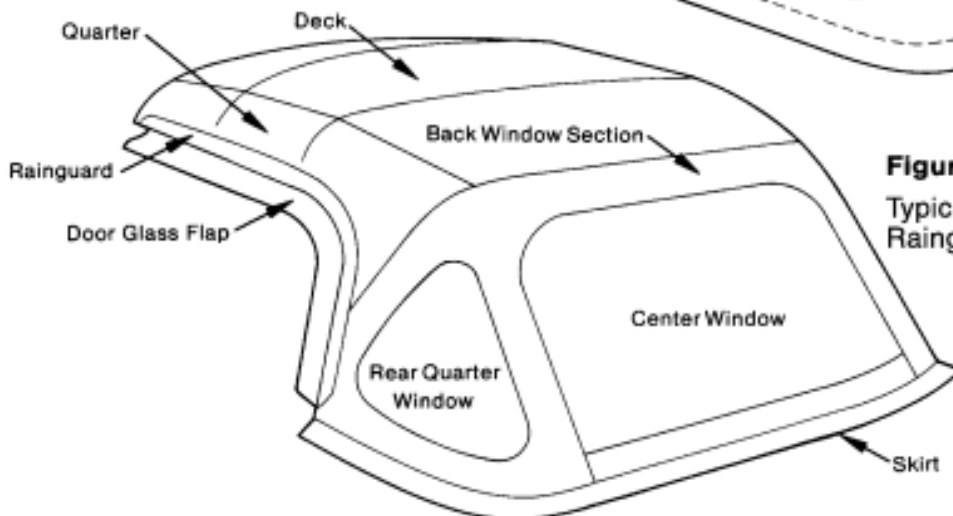
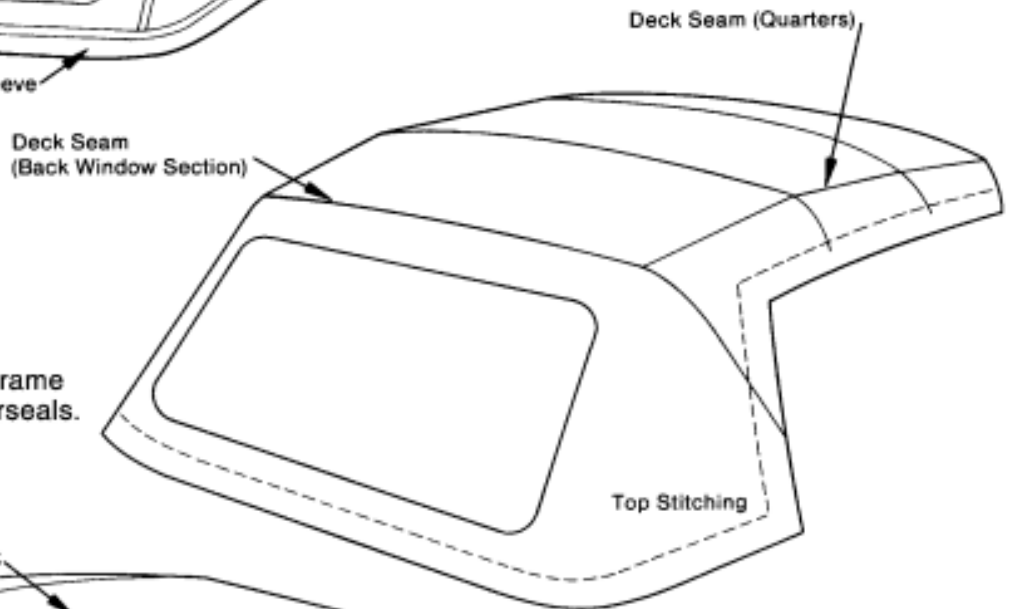

Figure 7:
Typical Import Car Top, with Flaps, Rainguard, and Skirt (British Style).